

Standard CPU Module Specifications

C0-01DD1-D

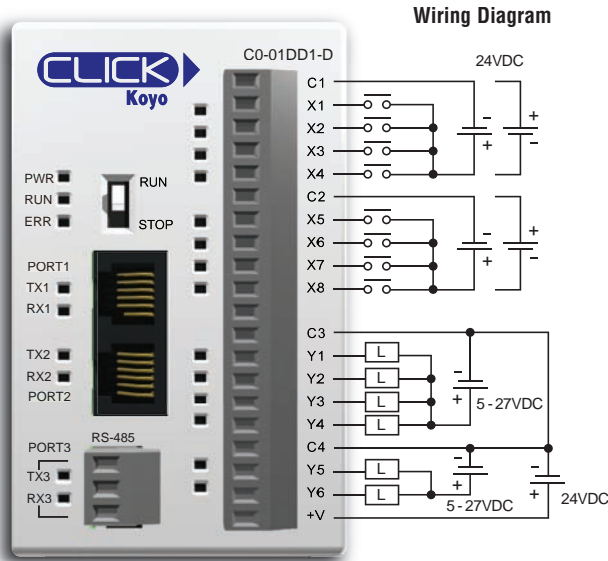

8 DC Input/6 Sinking DC Output Micro PLC



NOTE: When using Standard CPUs, you must use CLICK programming software version V1.20 or later.

Equivalent Input Circuit

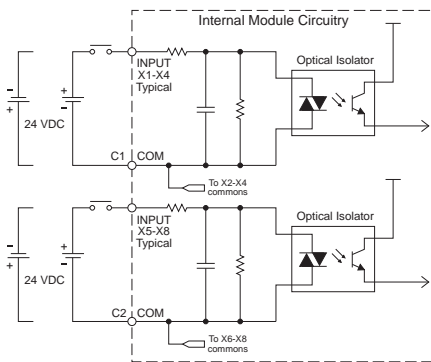

Equivalent Output Circuit

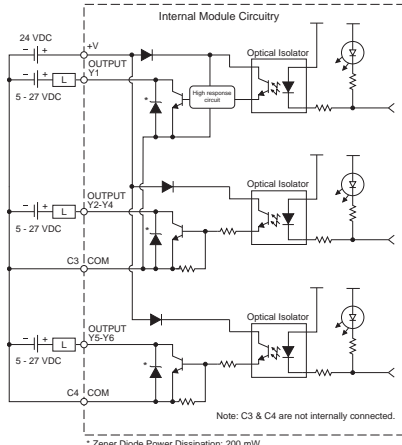

* Zener Diode Power Dissipation: 200 mW

C0-01DD1-D Built-in I/O Specifications - Inputs	
Inputs per Module	8 (Sink/Source)
Operating Voltage Range	24 VDC
Input Voltage Range	21.6 - 26.4 VDC
Input Current	X1-2: Typ 5 mA @ 24 VDC X3-8: Typ 4 mA @ 24 VDC
Maximum Input Current	X1-2: 6.0 mA @ 26.4 VDC X3-8: 5.0 mA @ 26.4 VDC
Input Impedance	X1-2: 4.7 kΩ @ 24 VDC X3-8: 6.8 kΩ @ 24 VDC
ON Voltage Level	X1-2: > 19 VDC X3-8: > 19 VDC
OFF Voltage Level	X1-2: < 4 VDC X3-8: < 7 VDC
Minimum ON Current	X1-2: 4.5 mA X3-8: 3.5 mA
Maximum OFF Current	X1-2: 0.1 mA X3-8: 0.5 mA
OFF to ON Response	X1-2: Typ 5 μs Max 20 μs X3-8: Typ 2 ms Max 10 ms
ON to OFF Response	X1-2: Typ 5 μs Max 20 μs X3-8: Typ 3 ms Max 10 ms
Status Indicators	Logic Side (8 points, green LED)
Commons	2 (4 points/common) Isolated

C0-01DD1-D Built-in I/O Specifications - Outputs	
Outputs per Module	6 (Sink)
Operating Voltage Range	5-27 VDC
Output Voltage Range	4-30 VDC
Maximum Output Current	0.1 A/point; C3: 0.4 A/common, C4: 0.2 A/common
Minimum Output Current	0.2 mA
Maximum Leakage Current	0.1 mA @ 30.0 VDC
On Voltage Drop	0.5 VDC @ 0.1 A
Maximum Inrush Current	150 mA for 10 ms
OFF to ON Response	Y1: typ 5 μs; max 20 μs Y2-6: < 0.5 ms
ON to OFF Response	Y1: typ 5 μs; max 20 μs Y2-6: < 0.5 ms
Status Indicators	Logic Side (6 points, red LED)
Commons	2 (4 points/com & 2 points/com)
External DC Power Required	20-28 VDC Maximum @ 60 mA (All Points On)

General Specifications

Current Consumption at 24VDC	140 mA
Terminal Block Replacement Part No.	C0-16TB
Weight	5.0 oz (140 g)

C0-01DD1-D Temperature Derating Chart

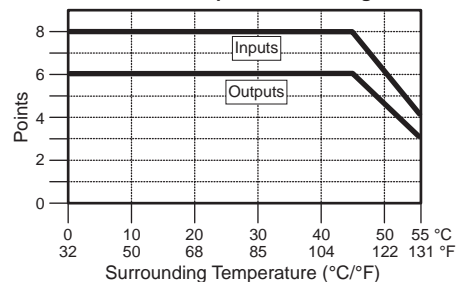

ZipLink Pre-Wired PLC Connection Cables and Modules

ZL-RTB20 20-pin feed-through connector module



20-pin connector cable
ZL-C0-CBL20 (0.5 m length)
ZL-C0-CBL20-1 (1.0 m length)
ZL-C0-CBL20-2 (2.0 m length)



CLICK Specifications

CPU Module Specifications

CPU Module Specifications			
	Basic CPU	Standard CPU	Analog CPU
Control Method	Stored Program/Cyclic execution method	Stored Program/Cyclic execution method	Stored Program/Cyclic execution method
I/O Numbering System	Fixed in Decimal	Fixed in Decimal	Fixed in Decimal
Ladder Memory (steps)	8000	8000	8000
Total Data Memory (words)	8000	8000	8000
Contact Execution (boolean)	< 0.6us	< 0.6us	< 0.6us
Typical Scan (1k boolean)	1-2 ms	1-2 ms	1-2 ms
RLL Ladder Style Programming	Yes	Yes	Yes
Run Time Edits	No	No	No
Scan	Variable / fixed	Variable / fixed	Variable / fixed
CLICK Programming Software for Windows	Yes	Yes	Yes
Built-in Communication Ports	Yes (two RS-232 ports)	Yes (two RS-232 ports and one RS-485 port)	Yes (two RS-232 ports and one RS-485 port)
FLASH Memory	Standard on CPU	Standard on CPU	Standard on CPU
Built-in Discrete I/O points	8 inputs, 6 outputs	8 inputs, 6 outputs	4 inputs, 4 outputs
Built-in Analog I/O Channels	No	No	2 inputs, 2 outputs
Number of Instructions Available	21	21	21
Control Relays	2000	2000	2000
System Control Relays	1000	1000	1000
Timers	500	500	500
Counters	250	250	250
Interrupt	Yes (external: 8 / timed: 4)	Yes (external: 8 / timed: 4)	Yes (external: 4 / timed: 4)
Subroutines	Yes	Yes	Yes
For/Next Loops	Yes	Yes	Yes
Math (Integer and Hex)	Yes	Yes	Yes
Drum Sequencer Instruction	Yes	Yes	Yes
Internal Diagnostics	Yes	Yes	Yes
Password Security	Yes	Yes	Yes
System Error Log	Yes	Yes	Yes
User Error Log	No	No	No
Memory Backup	Super Capacitor	Super Capacitor + Battery	Super Capacitor + Battery
Battery Backup	No	Yes (battery sold separately; part # D2-BAT-1)	Yes (battery sold separately; part # D2-BAT-1)
Calendar/Clock	No	Yes	Yes
I/O Terminal Block Replacement	ADC p/n C0-16TB	ADC p/n C0-16TB	ADC p/n C0-16TB
Communication Port & Terminal Block Replacement	N/A	ADC p/n C0-03TB	ADC p/n C0-03TB
24 VDC Power Terminal Block Replacement	ADC p/n C0-4TB	ADC p/n C0-4TB	ADC p/n C0-4TB

Field I/O

Software

C-more & other HMI

Drives

Soft Starters

Motors & Gearbox

Steppers/Servos

Motor Controls

Proximity Sensors

Photo Sensors

Limit Switches

Encoders

Current Sensors

Pressure Sensors

Temperature Sensors

Pushbuttons/Lights

Process

Relays/Timers

Comm.

Terminal Blocks & Wiring

Power

Circuit Protection

Enclosures

Tools

Pneumatics

Appendix

Product Index

Part # Index

CLICK Specifications

CPU Features

Basic and Standard CPUs

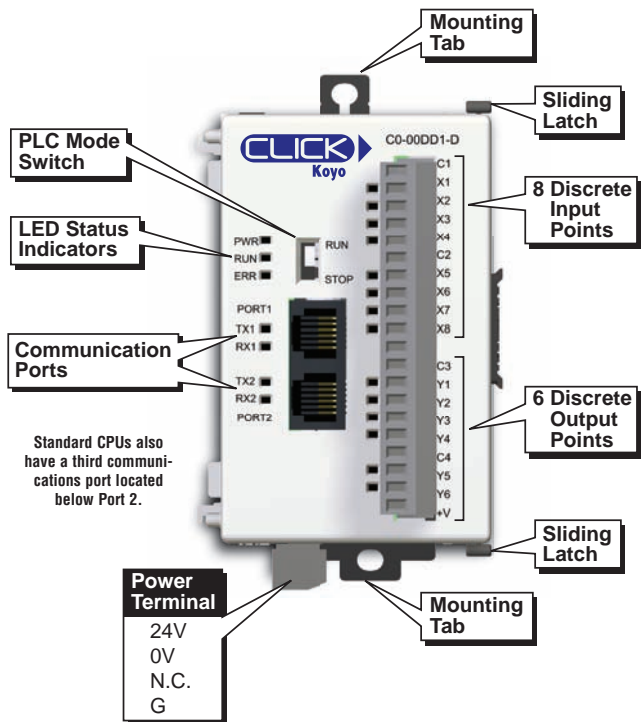

Analog CPUs

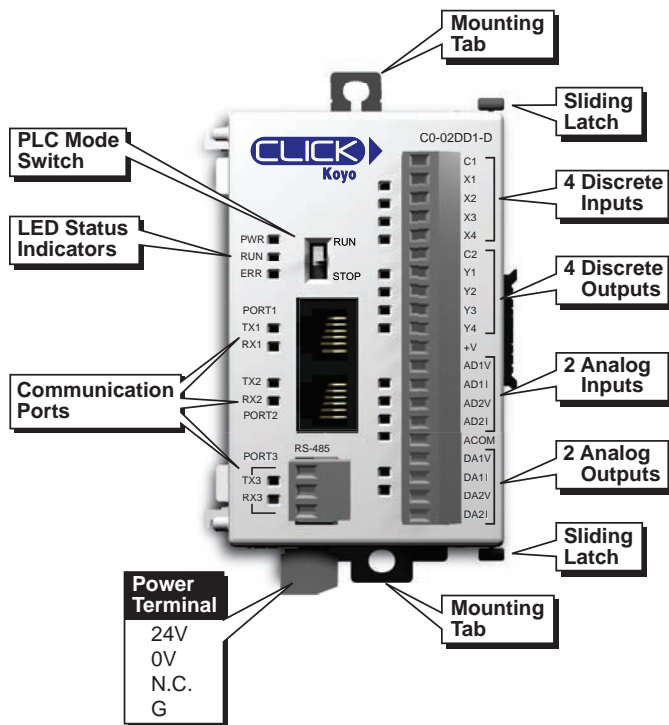

Bottom of CPU
(Same on all models)

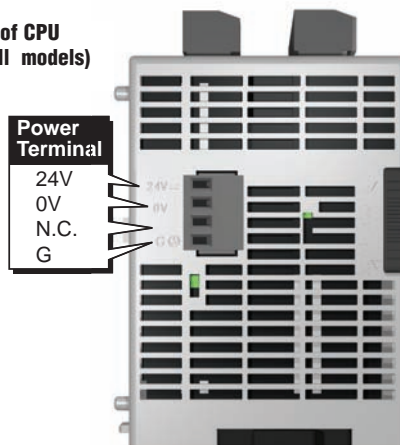

CLICK Specifications

CPU LED Status Indicators

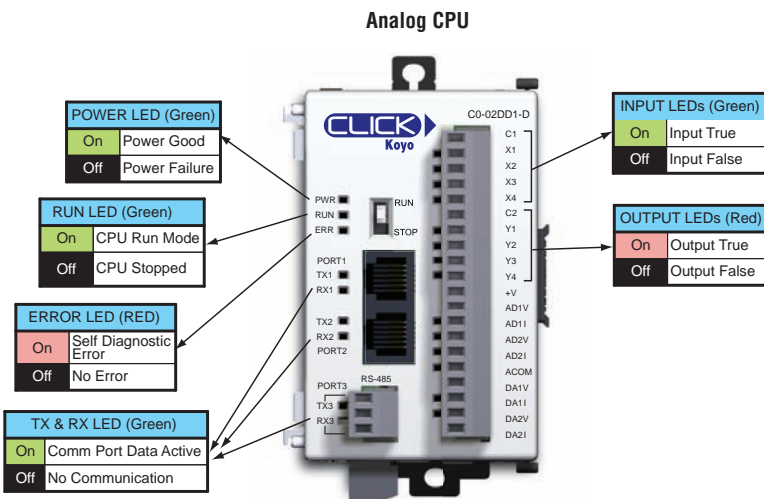
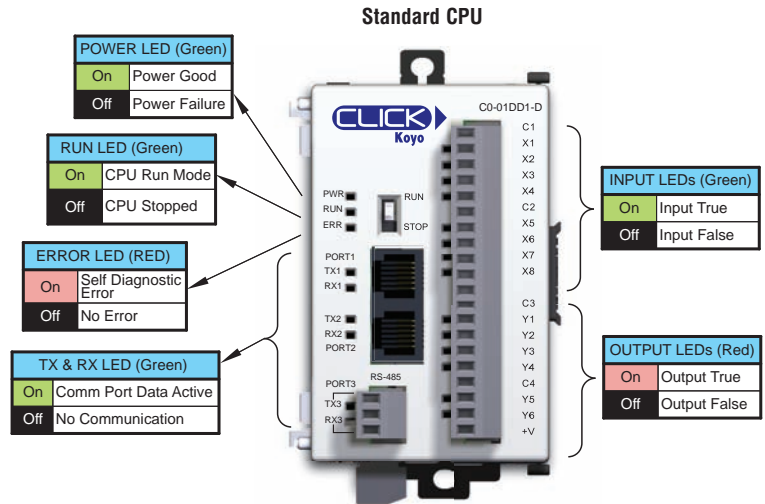
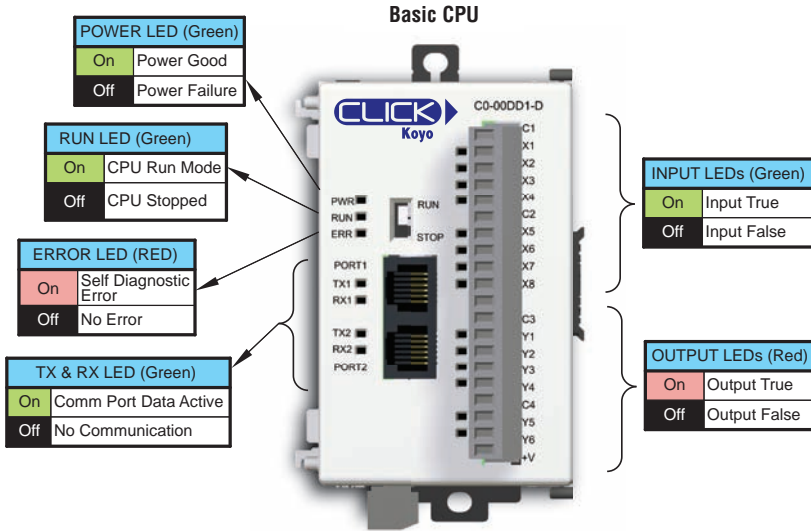

Product Dimensions and Installation

It is important to understand the installation requirements for your CLICK system. Your knowledge of these requirements will help ensure that your system operates within its environmental and electrical limits.

Plan for Safety

This catalog should never be used as a replacement for the user manual.

You can purchase, download free, or view online the user manuals for these products. Manual C0-USER-M is the user manual for the CLICK PLC. This user manual contains important safety information that must be followed. The system installation should comply with all appropriate electrical codes and standards.

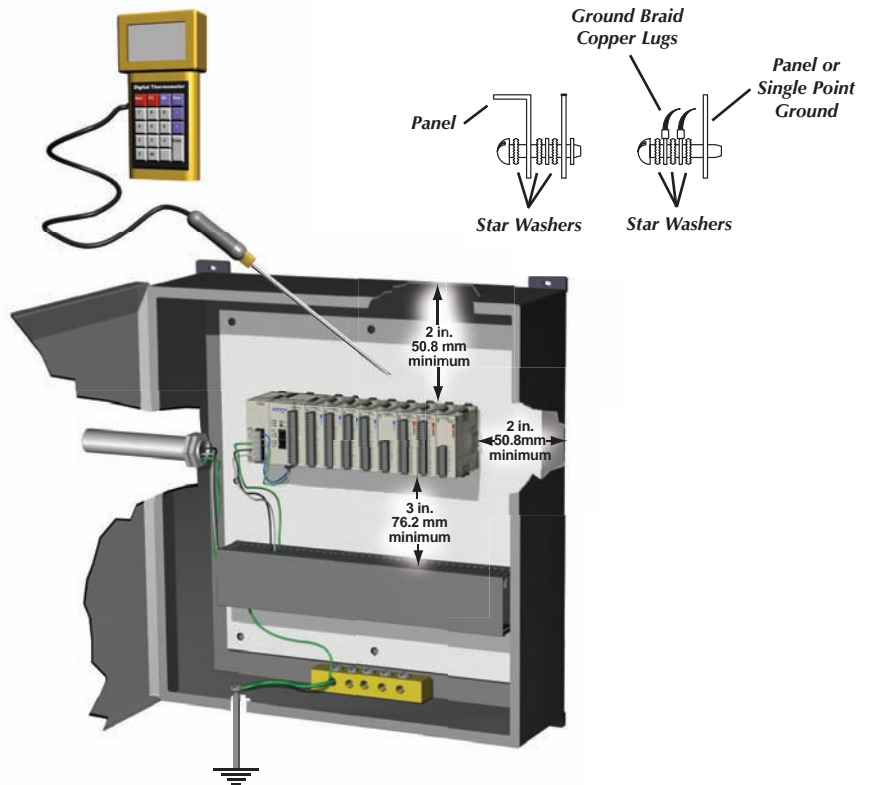

NOTE: THERE IS A MINIMUM CLEARANCE REQUIREMENT OF 2 INCHES (51 MM) BETWEEN THE CLICK PLC AND THE PANEL DOOR OR ANY DEVICES MOUNTED IN THE PANEL DOOR. THE SAME CLEARANCE IS REQUIRED BETWEEN THE PLC AND ANY SIDE OF THE ENCLOSURE. A MINIMUM CLEARANCE OF 3 INCHES (76 MM) IS REQUIRED BETWEEN THE PLC AND A WIREWAY OR ANY HEAT PRODUCING DEVICE.



Mounting Orientation

CLICK PLCs must be mounted properly to ensure ample airflow for cooling purposes. It is important to follow the unit orientation requirements and to verify that the PLC's dimensions are compatible with your application. Notice particularly the grounding requirements and the recommended cabinet clearances.

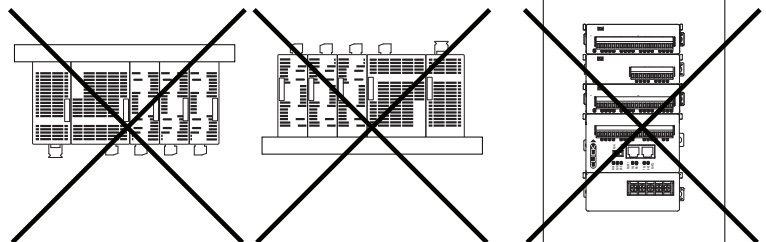
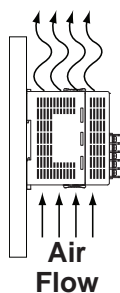

Product Dimensions and Installation

Connecting the Modules Together

CLICK CPUs, I/O modules and power supplies connect together using the extension ports that are located on the side panels of the modules (no PLC backplane/base required).

1. Remove extension port covers and slide the latch tabs forward.
2. Align the module pins and connection plug, and press the I/O module onto the right side of the CPU.
3. Slide the latch tabs backward to lock the modules together.

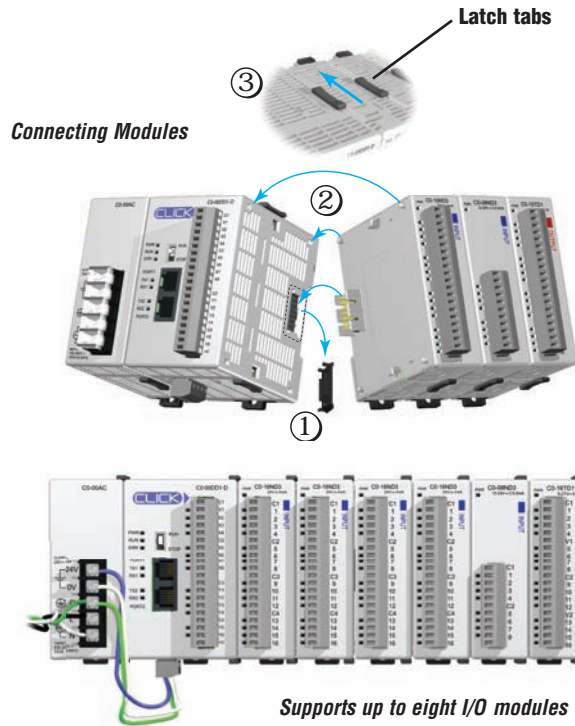

Mounting

The CLICK PLC system, which includes the CLICK power supplies, CPU modules, and I/O modules, can be mounted in one of two ways.

1. DIN rail mounted
2. Surface mounted using the built-in upper and lower mounting tabs.

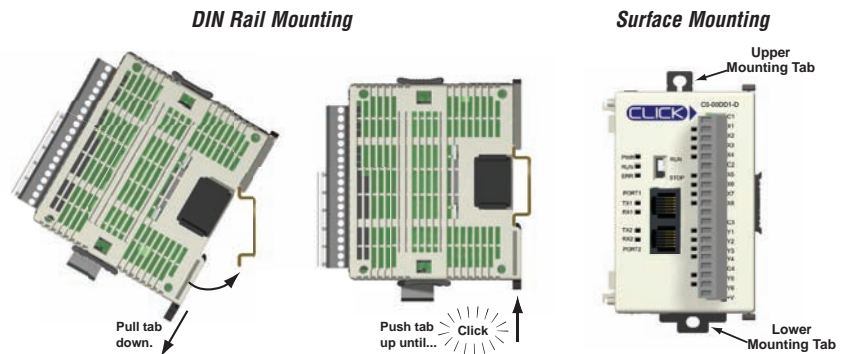

Unit Dimensions

These diagrams show the outside dimensions of the CLICK power supply, CPU, and I/O modules. The CLICK PLC system is designed to be mounted on standard 35mm DIN rail, or it can be surface mounted.

Allow proper spacing from other components within an enclosure.

Maximum system:

Power Supply + CPU + 8 I/O modules.

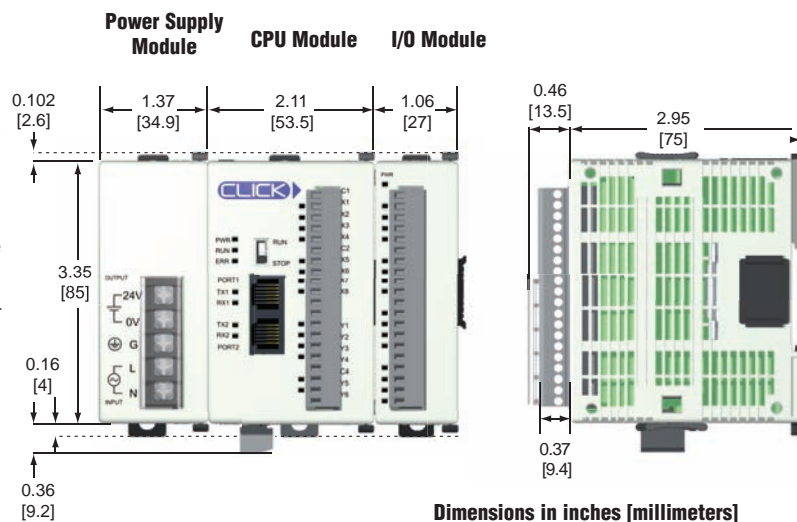

Product Dimensions and Installation

Unit Dimensions

Power Supply

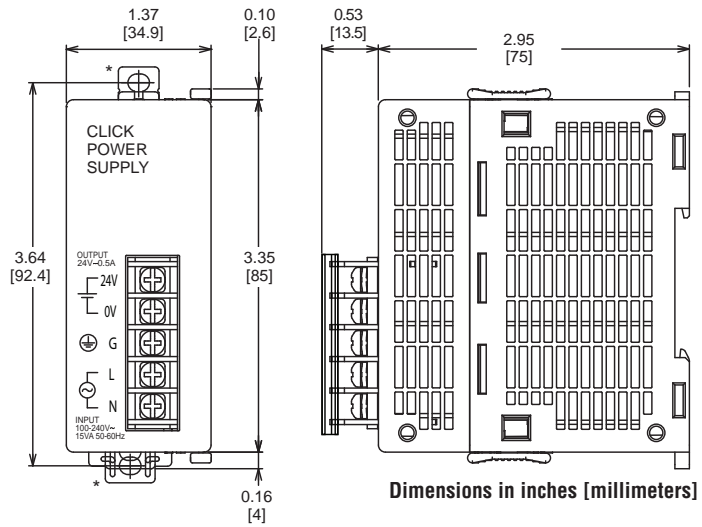

* Use size M4 screws for top and bottom mounting tab holes.

CPU Module

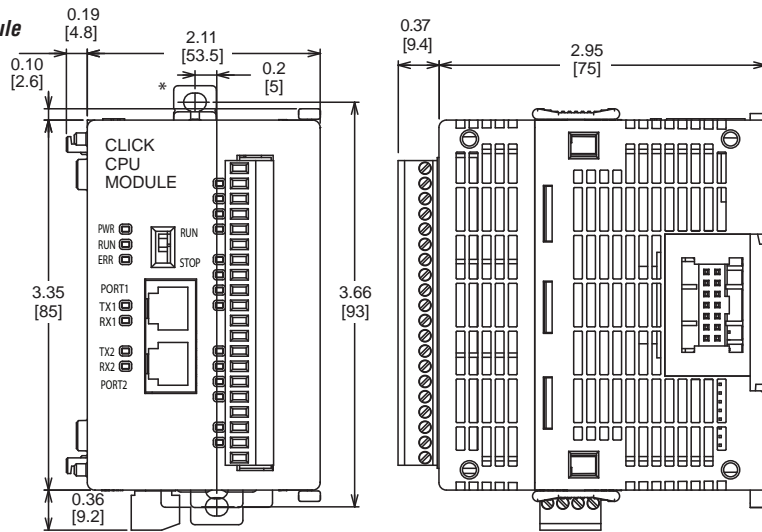

* Use size M4 screws for top and bottom mounting tab holes.

I/O Module

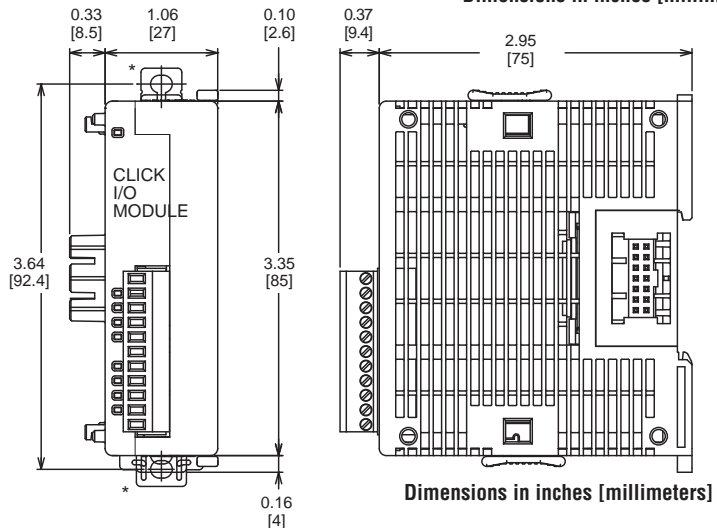

* Use size M4 screws for top and bottom mounting tab holes.

Networking the CLICK PLC

Built-in Communications Ports

All CPUs have two built-in RS-232 communications ports. Standard and Analog CPUs also have one built-in RS-485 communications port. One RS-232 port supports the Modbus RTU protocol only and can be used as the programming port. The other ports support either Modbus RTU or ASCII protocol. Both RS-232 ports supply 5 VDC, so you can connect a monochrome C-more Micro HMI panel without an additional power supply.

LED Status Indicators

There are LED indicators located to the left of each communication port to indicate when the port is transmitting or receiving.

Basic CPUs

Port 1 & 2 LED Status Indicators

TX1 and TX2 (Green)	
On	The Comm Port is sending data.
Off	The Comm Port is not sending data.
RX1 and RX2 (Green)	
On	The Comm Port is receiving data.
Off	The Comm Port is not receiving data.

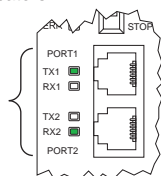

Standard and Analog CPUs

Port 1, 2, & 3 LED Status Indicators

TX1, TX2 and TX3 (Green)	
On	The Comm Port is sending data.
Off	The Comm Port is not sending data.
RX1, RX2 and RX3 (Green)	
On	The Comm Port is receiving data.
Off	The Comm Port is not receiving data.

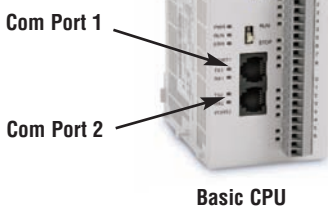
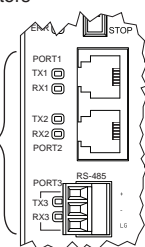

Basic CPU



Standard and Analog CPUs

Com Port 1 Specifications	
Use:	Programming Port
Physical:	6 pin, RJ12, RS-232
Communication speed (baud):	38400 (fixed)
Parity:	Odd
Station Address:	1
Data length:	8 bits
Stop bit:	1
Protocol:	Modbus RTU (slave only)

Port 1
6 pin RJ12 Phone Type Jack

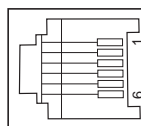

Port 1 Pin Descriptions		
1	0V	Power (-) connection (GND)
2	5V	Power (+) connection
3	RXD	Receive data (RS-232)
4	TXD	Transmit data (RS-232)
5	NC	No connection
6	0V	Power (-) connection (GND)

Com Port 2 Specifications	
Use:	Serial Communication
Physical:	6 pin, RJ12, RS-232
Communication speed (baud):	1200, 2400, 4800, 9600, 19200, 38400, 57600, 115200
Parity:	odd, even, none
Station Address:	1 to 247
Data length:	8 bits (Modbus RTU) or 7, 8 bits (ASCII)
Stop bit:	1,2
Protocol:	Modbus RTU (master/slave) or ASCII in/out

Port 2
6 pin RJ12 Phone Type Jack

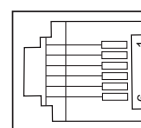

Port 2 Pin Descriptions		
1	0V	Power (-) connection (GND)
2	5V	Power (+) connection
3	RXD	Receive data (RS-232)
4	TXD	Transmit data (RS-232)
5	RTS	Request to send
6	0V	Power (-) connection (GND)

Com Port 3 Specifications	
Use:	Serial Communication
Physical:	3 pin, RS-485
Communication speed (baud):	1200, 2400, 4800, 9600, 19200, 38400, 57600, 115200
Parity:	odd, even, none
Station Address:	1 to 247
Data length:	8 bits (Modbus RTU) or 7, 8 bits (ASCII)
Stop bit:	1,2
Protocol:	Modbus RTU (master/slave) or ASCII in/out

Port 3
RS-485

Port 3 Pin Descriptions		
1	+ (plus)	Signal A (RS-485)
2	- (minus)	Signal B (RS-485)
3	LG	Logic Ground(0 V)

Port Setup

Use CLICK programming software to easily configure the communication ports.

