

Thermocouple Input Module

T1F-14THM <---->

14-channel thermocouple input module

The 14-channel thermocouple input module uses a T1K-16B screw-type terminal base only, which is purchased separately.

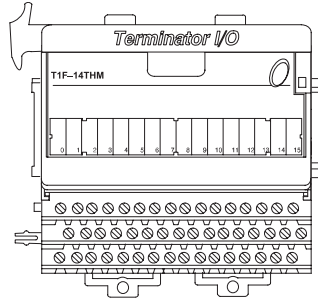

T1F-14THM 14-Channel Thermocouple Input Specifications	
Use I/O Base	T1K-16B Only
Number of Channels	14, differential
Common Mode Range	±5 VDC
Common Mode Rejection	90 dB min. @ DC, 150 dB min. @ 50/60 Hz.
Input Impedance	1 MΩ
Absolute Maximum Ratings	Fault-protected inputs to ±50 VDC
Accuracy vs. Temperature	±5 ppm/°C maximum full scale calibration. (including maximum offset change)
Master Update Rate	14 channels per scan max.
Input Points Required	512 Discrete I/O points /16 Double Words Network Interface Dependent
External Module Power Required	70mA maximum, 24VDC ± 5%
Base Power Required	60 mA max., 5 VDC
Operating Temperature	32° to 140°F (0° to 60°C)
Storage Temperature	-4° to 158°F (-20° to 70°C)
Relative Humidity	5 to 95% (non-condensing)
Environmental Air	No corrosive gases permitted
Vibration	MIL STD 810C 514.2
Shock	MIL STD 810C 516.2
Noise Immunity	NEMA ICS3-304
Weight	168 g

Thermocouple Specifications (Cont.)	
Input Ranges	Type J -190 to 760°C -310 to 1400°F
	Type E -210 to 1000°C -346 to 1832°F
	Type K -150 to 1372°C -238 to 2502°F
	Type R 65 to 1768°C 149 to 3214°F
	Type S 65 to 1768°C 149 to 3214°F
	Type T -230 to 400°C -382 to 752°F
	Type B 529 to 1820°C 984 to 3308°F
Type N -70 to 1300°C -94 to 2372°F	
Type C 65 to 2320°C 149 to 4208°F	
Display Resolution	±0.1 °C or ±0.1 °F
Cold Junction Compensation	Automatic; CJC (part #: T1F-CJC) included with module must be installed in terminal base (refer to the module's data sheet)
Conversion Time	100 ms
Warm-Up Time	30 minutes typically ± 1°C repeatability
Linearity Error (End to End)	±.05 °C maximum, ±.01°C typical
Maximum Inaccuracy	±3 °C (excluding thermocouple error)
Voltage Input Specifications	
Voltage Ranges	0-5 V, ±5V, 0-156.25 mV, ±156.25 mVDC
Resolution	16 bit (1 in 65535)
Full Scale Calibration Error (Offset Error Included)	±13 counts typical ±33 maximum
Offset Calibration Error	±1 count maximum, @ 0V input
Linearity Error (End to End)	±1 count maximum
Maximum Inaccuracy	±0.02% @ 25°C (77°F)

Notes:

- 1: Shields should be grounded at the signal source.
- 2: Connect unused inputs to a common terminal (0 VDC).
- 3: When using 0-156 mV and 5V ranges, connect (-) or (0) volts terminal to 0V to ensure common mode range acceptance.
- 4: The Cold Junction Compensation (CJC) temperature sensing unit must be installed into the I/O base terminals to perform CJC of the thermocouple inputs.

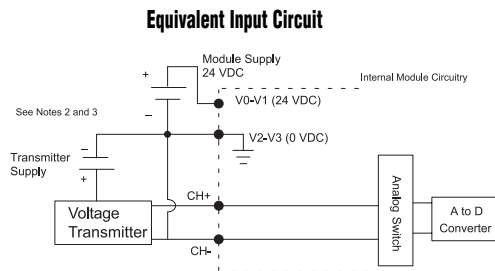
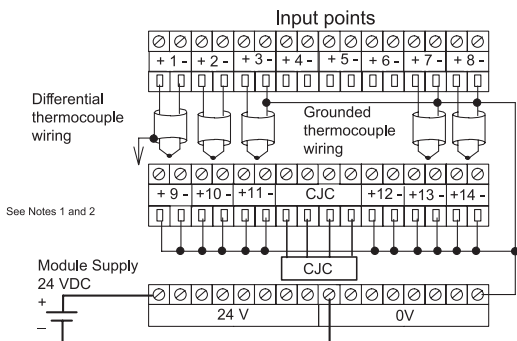

- PLC Overview
- DL05/06 PLC
- DL105 PLC
- DL205 PLC
- DL305 PLC
- DL405 PLC
- Field I/O**
- Software
- C-more HMIs
- Other HMI
- AC Drives
- Motors
- Steppers/Servos
- Motor Controls
- Proximity Sensors
- Photo Sensors
- Limit Switches
- Encoders
- Pushbuttons/Lights
- Process
- Relays/Timers
- Comm.
- TB's & Wiring
- Power
- Enclosures
- Appendix
- Part Index